

ISSUE	AUTHOR	DETAIL OF CHANGE	ECO REF	DATE
A	RBR	FOR ISSUE	~	n.a.

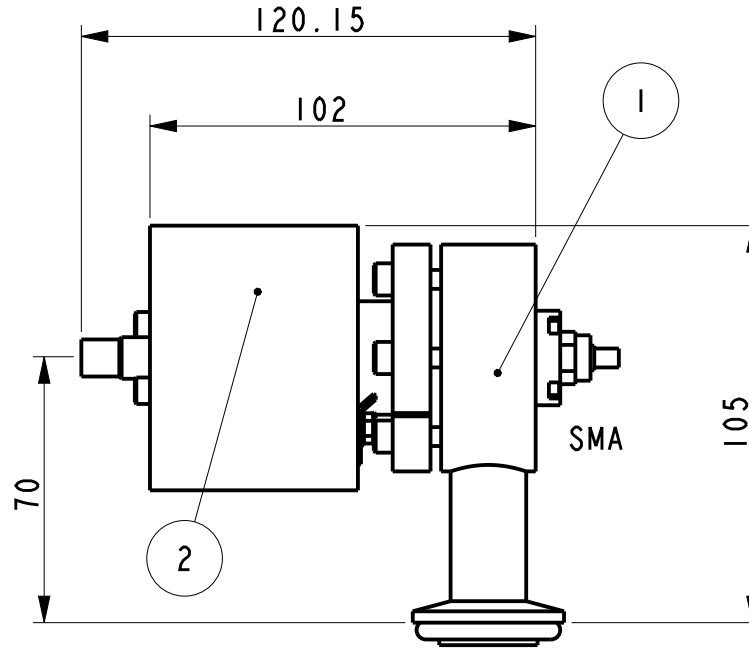
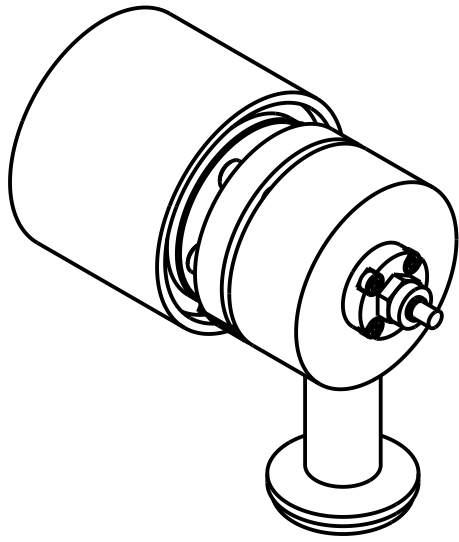

ITEM	DRAWING	DESCRIPTION	TYPE	SUPPLIER	QTY
1	OPX-03-C01	Plasma Tee Assy	ASSEMBLY	Genco	1
2	OPX-CC	Plasma Generator	ASSEMBLY	Genco	1

FIRST ANGLE		ORIGINAL SCALE 1:2	DRAWING NUMBER		
DRAWN BY Robert Brown		DATE 21-01-21	<h1>OPTIX-SMA</h1> <p>OPTIX for remote viewing</p>		
MAKE FROM Various		ORIGINAL SHEET SIZE A4			
TREATMENT/HARDNESS/FINISH Supplier Type: Genco		ANGLE TOLERANCES ± 0° 30' UNLESS OTHERWISE STATED.	ALL HOLES Ø 0.2	INITIAL STATE OF SURFACE MUST BE FREE FROM INDENTATIONS, GOUGES AND SCRATCHES.	ALL DIMENSIONS EXPRESSED IN mm UNLESS OTHERWISE STATED.
PERMITTED GENERAL TOLERANCES UNLESS OTHERWISE STATED; FABRICATIONS ± 1		0. ± 0.2 .0 ± 0.1 .00 ± 0.05 .000 ± 0.005	<b>DO NOT SCALE</b> COPYRIGHT: THIS DRAWING IS COPYRIGHT & PROPERTY OF GENCOA LTD. IT MUST NOT BE COPIED, USED FOR MANUFACTURE OR OTHERWISE DISCLOSED WITHOUT PRIOR WRITTEN CONSENT OF THE COMPANY. ©Genco Ltd 1995.		
CHECKED BY n.a.	CHECK DATE n.a.	DESIGN APPROVED BY n.a.	APPROVAL DATE n.a.	SHEET 1 OF 1	